



.....

Marathon 2130sl

.....

Marathon 1420sl

.....

ATA Interface Drives

.....

.....

Product Manual

.....

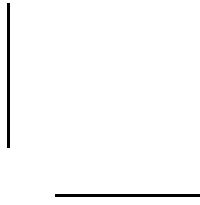
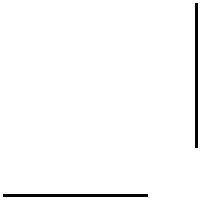

.....
Marathon 2130sl (ST92130AG)
.....

Marathon 1420sl (ST91420AG)
.....

ATA Interface Drives
.....

.....
Product Manual
.....



©1997 Seagate Technology, Inc. All rights reserved

Publication Number: 20401053-001, Rev. A, March 1997

Seagate, Seagate Technology, the Seagate logo, Marathon and SafeRite are either trademarks or registered trademarks of Seagate Technology, Inc. Other product names are registered trademarks or trademarks of their owners.

Seagate reserves the right to change, without notice, product offerings or specifications. No part of this publication may be reproduced in any form without written permission from Seagate Technology, Inc.

Contents

Introduction	1
Specification summary table	2
1.0 Drive specifications	5
1.1 Formatted capacity	5
1.1.1 Default logical geometry	5
1.1.2 Supported translation geometries	6
1.2 Physical organization	6
1.3 Recording and interface technology	6
1.4 Physical characteristics	7
1.5 Seek time	7
1.6 Start times	8
1.7 Power specifications	8
1.7.1 Power consumption	8
1.7.2 Power recovery	9
1.7.3 Conducted noise	10
1.7.4 Voltage tolerance	10
1.7.5 Power-management modes	10
1.8 Environmental tolerances	12
1.8.1 Ambient temperature	12
1.8.2 Temperature gradient	12
1.8.3 Humidity	12
1.8.4 Altitude	13
1.8.5 Shock	13
1.8.6 Vibration	13
1.9 Drive acoustics	14
1.10 Reliability	15
1.11 Agency certification	15
1.11.1 Safety certification	15

1.11.2 Electromagnetic Compatibility	15
1.11.3 FCC verification	16
2.0 Drive mounting and configuration	17
2.1 Handling and static-discharge precautions	17
2.2 Jumper settings	17
2.2.1 Master/slave configuration	17
2.3 Remote LED configuration	19
2.4 Drive mounting	19
2.5 ATA interface connector	23
3.0 ATA Attachment-3 Interface (ATA-3)	25
3.1 ATA interface signals and connector pins	25
3.1.1 AT bus signal levels	25
3.2 ATA Interface commands	27
3.2.1 Supported ATA commands	27
3.2.2 Identify Drive command	29
3.2.3 Set Features command	32
3.2.4 S.M.A.R.T. commands	34
3.2.5 Drive-Security commands	35
Appendix. Compatibility notes	37

Figures

Figure 1. Typical startup and operation current profile.	9
Figure 2. Connector and master/slave jumper setup	18
Figure 3. Drive mounting dimensions—side and bottom view.	20
Figure 4. Drive mounting dimensions—end view	21
Figure 5. ATA Interface connector dimensions	23
Figure 6. I/O pins and supported ATA signals	26

Introduction

The Marathon™ 2130sl (ST92130AG) and 1420sl (ST91420AG) provide very high storage capacity in a small, low-profile hard disc drive.

Key Features:

- Low power consumption
- Low profile (12.7-mm high); compact, SFF-8200-compatible form-factor
- Quiet operation
- SafeRite™ shock protection
- High instantaneous (burst) data-transfer rates (up to 16.6 Mbytes per second) using PIO mode 4 and DMA mode 2
- 103-Kbyte adaptive multisegmented cache
- Improved caching and on-the-fly error-correction algorithms
- Support for PIO modes 0, 1, 2, 3 and 4, as well as single-word and multiword DMA modes 0, 1 and 2
- Support for S.M.A.R.T. drive monitoring and reporting
- Support for drive password security
- Support for Read/Write Multiple commands
- Support for autodetection of master/slave drives using cable-select (CSEL) and DASP– signals

Specification summary table

The specifications listed in this table are for quick reference. For details on specification measurement or definition, see the appropriate section of this manual.

Drive Specification	2130sl	1420sl
Guaranteed Mbytes (1 Mbyte=10 ⁶ bytes)	2,163	1,441
Guaranteed sectors (LBA mode)	4,224,878	2,816,352
Bytes per sector	512	
Default sectors per track	63	
Default read/write heads	16	
Default cylinders	4,191	2,794
Physical read/write heads	6	4
Discs	3	2
Recording density (bits/inch max)	154,000	
Track density (tracks/inch)	7,194	
Areal density (Mbits/inch ² max)	1,108	
Spindle speed (RPM)	4,508	
Internal data-transfer rate (Mbits/sec max)	71.3	
I/O data-transfer rate (Mbytes/sec max)	16.6	
ATA data-transfer modes supported	PIO modes 0, 1, 2, 3, 4 and multiword DMA modes 0, 1, 2	
Cache buffer (Kbytes)	103	
Height (mm max)	12.7	
Width (mm max)	70.1	
Length (mm max)	100.94	
Weight (grams max)	165	160

Drive Specification	2130sl	1420sl
Track-to-track seek time (msec typical)	4 (read), 5 (write)	
Average seek time (msec typical)	12 (read), 14 (write)	
Full-stroke seek time (msec max)	26 (read), 28 (write)	
Average latency (msec)	6.66	
Power-on to ready (sec typical)	3	
Standby to ready (sec typical)	2	
Spinup current (peak)	1.1 amps	
Read/Write power and current (typical)	2.4 watts, 0.48 amps	
Seek power and current (typical)	2.3 watts, 0.46 amps	
Idle mode power and current (typical)	1.0 watts, 0.20 amps	
Standby mode power and current (typical)	0.3 watts, 0.06 amps	
Sleep mode power and current (typical)	0.16 watts, 0.033 amps	
Voltage tolerance (including noise)	+5 volts, $\pm 5\%$	
Ambient temperature ($^{\circ}\text{C}$)	5 to 60 (op.), -40 to 70 (nonop.)	
Temperature gradient ($^{\circ}\text{C}$ per hour max)	30	
Relative humidity (operating)	8% to 80% (10% per hour max grad.)	
Wet bulb temperature ($^{\circ}\text{C}$ max)	29.4 (op.), 40 (nonop.)	
Altitude (meters above mean sea level max)	-300 to 3,040 (op.), -300 to 12,190 (nonop.)	
Shock, operating (Gs max)	125 (2 msec)	
Shock, nonoperating (Gs max, 2 msec)	350	

Drive Specification	2130sl	1420sl
Vibration (Gs max at 5–400 Hz, without physical damage or loss of data)	0.75 (op.) 4.0 (nonop.)	
Drive acoustics (bels—sound power) Idle mode (dBA—sound pressure)	3.5 (typical), 3.8 (max) 24 (typical), 28 (max)	
Drive acoustics (bels—sound power) Seek mode (dBA—sound pressure)	3.8 (typical), 4.1 (max) 26 (typical), 30 (max)	
Nonrecoverable read errors	1 per 10 ¹³ bits read	
Mean time between failures (power-on hours) at 40°C	350,000	
Contact start-stop cycles (40°C, ambient humidity)	50,000	
Service life (years)	5	

1.0 Drive specifications

Unless otherwise noted, all specifications are measured under ambient conditions, at 40°C, at sea level and nominal power.

1.1 Formatted capacity

	2130sl	1420sl
Guaranteed Kbytes	2,163,137.5	1,441,972.2
Guaranteed sectors (LBA mode)	4,224,878	2,816,352
Bytes per sector	512	512

Note. DOS systems cannot access more than 528 Mbytes unless 1) the host system supports and is configured for LBA addressing or for extended CHS addressing, or 2) the host system contains a specialized drive controller, or 3) the host system runs BIOS translation software. Contact your Seagate® representative for details.

1.1.1 Default logical geometry

CHS Mode	2130sl	1420sl
Sectors per track	63	63
Read/write heads	16	16
Cylinders	4,191	2,794

LBA Mode

When addressing any model in LBA mode, all blocks (sectors) are consecutively numbered from 0 to $n - 1$.

1.1.2 Supported translation geometries

The Marathon 2130sl and 1420sl support any translation geometry that satisfies *all* of the following conditions:

	2130sl	1420sl
Sectors per track	≤ 63	≤ 63
Read/write heads	≤ 16	≤ 16
Total cylinders (CHS)*	≤ 4,224,528	≤ 2,816,352
Total cylinders (LBA)*	≤ 4,224,878	≤ 2,816,352

*Total cylinders = (sectors per track) (read/write heads) (cylinders)

1.2 Physical organization

Read/Write heads	6	4
Discs	3	2

1.3 Recording and interface technology

	2130sl/1420sl
Interface	ATA
Recording method	16/17
Recording density (bits/inch max)	154,000
Track density (tracks/inch)	7,194
Areal density (Mbits/inch ² max)	1,108
Spindle speed (RPM) (± 0.5%)	4,508
Internal data-transfer rate (Mbits per sec max)	71.3
I/O data-transfer rate (Mbytes per sec max)	16.6 (PIO mode 4 with IORDY) 16.6 (multiword DMA mode 2)
Interleave	1:1
Cache buffer (Kbytes)	103

1.4 Physical characteristics

		2130sl	1420sl
Maximum height	(mm)	12.70	12.70
	(inches)	0.500	0.500
Maximum width	(mm)	70.1	70.1
	(inches)	2.76	2.76
Maximum length	(mm)	100.94	100.94
	(inches)	3.974	3.974
Maximum weight	(grams)	165	160
	(ounces)	5.82	5.64

1.5 Seek time

All seek times are measured using a 25 MHz 486 AT computer (or faster) with an 8.3 MHz I/O bus. The measurements are taken with nominal power at sea level. The specifications in the table below are defined as follows:

- Track-to-track seek time is an average of all possible single-track seeks in both directions.
- Average seek time is a true statistical random average of at least 5,000 measurements of seeks between random tracks, less overhead.
- Full-stroke seek time is one-half the time needed to seek from the first data cylinder to the maximum data cylinder and back to the first data cylinder. The full-stroke typical value is determined by averaging 100 full-stroke seeks in both directions.

Seek type	Typical read (msec)	Typical write (msec)
Track-to-track	4	5
Average	12	14
Full-stroke (max)	26	28

Average latency: 6.65 msec

1.6 Start times

Power-on to Ready (sec)	3 typical
Standby to Ready (sec)	2 typical
Idle to Ready (sec)	0.4 typical

1.7 Power specifications

The drive receives DC power (+5V) through pin 41 and pin 42 of the AT interface connector.

1.7.1 Power consumption

Power requirements for the drive are listed in the table below. Typical power measurements are based on an average of drives tested under nominal conditions, using 5.0V input voltage at 25°C ambient temperature at sea level. Unless specified as peak, all other measurements are RMS. Active mode current and power are measured with an 8-msec delay between each operation and the drive in default logical geometry. Seeking power and currents are measured during random seeks. Read/write power and current are measured with the heads on track, based on a 16-sector write followed by a 16-sector read. Spinup power is measured from typical time of power-on to time of drive-ready for normal operation.

Mode	Watts (at nominal voltage)		Amps (at nominal voltage)	
	Typical	Max	Typical	Max
Spinup				
Peak	—	—		1.1
Average	3.0	—	0.6	—
Active				
Read/Write	2.4	2.5	0.48	0.50
Seek	2.3	2.5	0.46	0.50
Idle	1.0	1.15	0.20	0.23
Standby	0.3	0.35	0.06	0.07
Sleep	0.16	0.18	0.033	0.036

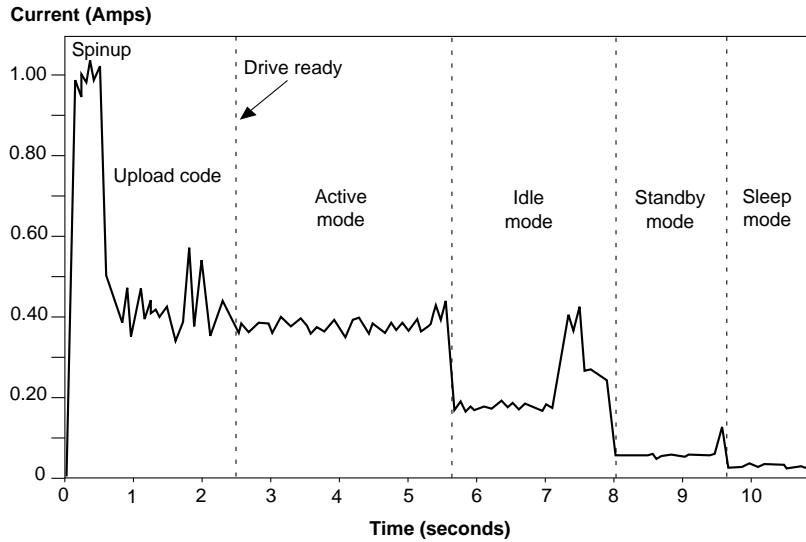

Figure 1. Typical startup and operation current profile

1.7.1.1 Typical current profile

Figure 1 shows a typical drive startup and operation current profile for the Marathon 2130sl and 1420sl.

Note. The peaks in this profile are the result of inductive kickback from the commutation of the spindle motor and, therefore, do not draw power from the battery. The average peak represents peak power that is drawn from the battery.

1.7.2 Power recovery

Except during execution of a write command or writing cached data, the drive's power can be interrupted without adversely affecting the drive or previously written data. If power is removed while the drive is performing a write operation, the integrity of the data being written cannot be guaranteed.

Note. Do not remove power from the drive while keeping the interface signals active (at low impedance). Power may enter the input buffers.

1.7.3 Conducted noise

The drive is expected to operate with a maximum of:

- 150 mV peak-to-peak triangular-wave injected noise at the power connector. The frequency is 10 Hz to 100 KHz with equivalent resistive loads.*
- 100 mV peak-to-peak triangular-wave injected noise at the power connector. The frequency is 100 KHz to 10 MHz with equivalent resistive loads.*

* Equivalent resistance (10 ohms) is calculated by dividing the nominal voltage (5V) by the typical RMS read/write current (0.5 amps).

1.7.4 Voltage tolerance

Voltage tolerance (including noise): +5 volts, \pm 5%

1.7.5 Power-management modes

Seagate's Marathon drives provide programmable power management to enhance battery life and to provide greater energy efficiency. In most computers, you can control power management through the system setup program. These drives feature several power-management modes, which are summarized in the following table and described in more detail below:

Mode	Heads	Spindle	Buffer
Active	Moving	Rotating	Enabled
Idle	Varies	Rotating	Enabled
Standby	Parked	Stopped	Enabled
Sleep	Parked	Stopped	Disabled

Active mode. The drive is in Active mode during the read/write and seek operations.

Idle mode. At power-on, the drive sets the Idle Timer to enter Idle mode after 5 seconds of inactivity. The drive remains in Idle mode with heads flying over the media for 15 minutes; then the drive makes the transition to Active mode and seeks to the last known logical block address, where it remains for 5 minutes. The drive then seeks to a new, unspecified location two more times, for 5 minutes each, after which it makes the transition to Standby mode. In Idle mode, the spindle remains up to speed, the buffer remains enabled, and the drive accepts all commands and returns to Active mode whenever a disc access command is received.

The drive enters Idle mode when an Idle or Idle Immediate command is received. The Idle or Idle Immediate command overrides the algorithm described above. The drive remains in Idle mode until a disc access command is received or the standby timer expires, whichever occurs first. When the standby timer expires, the drive makes the transition to the Standby mode. The drive requires approximately 400 msec to return to Active mode from Idle mode.

Standby mode. The drive enters Standby mode when the host sends a Standby or Standby Immediate command. If the standby timer has been set by the Standby command, the drive enters Standby mode automatically after the drive has been inactive for the specified length of time. In Standby mode, the buffer remains enabled, the heads are parked and the spindle is at rest. The drive accepts all commands and returns to Active mode any time a disc access command is received. The drive requires approximately 3 seconds to return to Active mode from Standby mode.

Sleep mode. The drive enters Sleep mode only after receiving a Sleep command from the host. The heads are parked and the spindle is at rest. The ROM and RAM codes are valid; however, the cache is flushed before the drive enters Sleep mode. The drive leaves Sleep mode when either a Hard Reset interface signal or a Soft Reset signal (Device Control register=04) is received from the host. After receiving a Soft Reset, the drive exits Sleep mode and enters Standby mode, with all current emulation and translation parameters intact. After receiving a Hard Reset signal, the drive exits Sleep mode and enters Active mode. The drive is reinitialized to the default parameters. This is the same procedure as initial power on and typically requires 3 seconds to complete.

Idle and standby timers. The drive sets the default time delay for the idle timer at power-on to 5 seconds. If the idle timer reaches zero before any drive activity is required, the drive makes a transition to Idle mode. Each time the drive performs an Active function (read, write or seek), the idle and standby timers are reinitialized and begin counting down from their specified delay times to zero. If the standby timer has been set and no additional drive activity occurs, the drive remains in Idle mode for the time specified in the standby timer, then enters Standby mode.

If the host has not set the standby timer and no additional drive activity occurs, the drive remains in Idle mode for 30 minutes, then enters standby mode. In both Idle and Standby mode, the drive accepts all commands and returns to Active mode when disc access is necessary.

Note to system developers. When designing power-management routines and hardware, you must make sure that the drive has completed its power mode transition before issuing hardware or software resets or removing power from the ATA interface.

If write caching is active, the drive must have time to flush the cache to the disc before resets or power removal occurs. When the Standby or Standby Immediate command is issued, the drive sets BSY status, flushes the cache to disc, clears BSY status and then issues an interrupt to the host computer. Therefore, the host computer must wait for this interrupt before issuing resets or removing power from the drive. Failing to observe this procedure may result in data corruption on the drive. Issuing resets or turning off power to the drive without first issuing a Standby or Standby Immediate command to flush the cache also leaves corrupted data on the drive if the write cache has active data in it.

Under normal circumstances, the Standby or Standby Immediate commands take approximately 700–800 msec to complete. However, they can take longer if error recovery is used. Therefore, it is not a good programming practice to use a timing loop to determine when these commands should be complete. Waiting for the interrupt is the safe, closed-loop method to know when a reset can be issued or power can be turned off.

1.8 Environmental tolerances

1.8.1 Ambient temperature

Operating	5° to 60°C (41° to 140°F)
Nonoperating	–40° to 70°C (–40° to 158°F)

Caution. This drive needs sufficient airflow so that the maximum surface temperature at the center of the top cover of the drive does not exceed 62 degrees C (144 degrees F).

1.8.2 Temperature gradient

Operating	30°C / hr (86°F / hr) max, without condensation
Nonoperating	30°C / hr (86°F / hr) max, without condensation

1.8.3 Humidity

1.8.3.1 Relative humidity

Operating	8% to 80% noncondensing (10% per hour max)
Storage	5% to 95% noncondensing (10% per hour max)
Transit	5% to 95% noncondensing (10% per hour max)

1.8.3.2 Wet bulb temperature

Operating	29.4°C (85°F) max
Nonoperating	40°C (104°F) max

1.8.4 Altitude

Operating	–300 m to 3,040 m (–1,000 ft to 10,000 ft)
Nonoperating	–300 m to 12,190 m (–1,000 ft to 40,000 ft)

1.8.5 Shock

For all shock specifications, it is assumed that the drive is mounted securely with the input levels at the drive mounting screws. For the nonoperating specifications, it is assumed that the read/write heads are positioned in the shipping zone.

Note. At power-down, the read/write heads automatically move to the shipping zone. The head assembly parks outside of the maximum data cylinder. When power is applied, the heads recalibrate to Track 0.

1.8.5.1 Operating shock

The Marathon 2130sl and 1420sl incorporate SafeRite shock protection and can withstand a maximum operating shock of 125 Gs without nonrecoverable data errors (based on half-sine shock pulses of 2 msec).

1.8.5.2 Nonoperating shock

The nonoperating shock level that the Marathon 2130sl and 1420sl can experience without incurring physical damage or degradation in performance is 350 Gs (based on half-sine shock pulses of 2 msec duration) or 150 Gs (based on half-sine shock pulses of 11 msec duration). Shock pulses are defined by MIL-STD-202 F with the amplitude tolerance controlled to $\pm 5\%$.

1.8.6 Vibration

For all vibration specifications, it is assumed that the drive is mounted in an approved orientation with the input levels at the drive mounting screws. For the nonoperating specifications, it is assumed that the read/write heads are positioned in the shipping zone.

1.8.6.1 Operating vibration

The following table lists the maximum vibration levels that the drive may experience without incurring physical damage, data loss or performance degradation.

5–22 Hz	0.02-inch displacement (peak-to-peak)
22–400 Hz	0.75 Gs acceleration (0 to peak)
400–22 Hz	0.75 Gs acceleration (0 to peak)
22–5 Hz	0.02-inch displacement (peak-to-peak)

1.8.6.2 Nonoperating vibration

The following table lists the maximum nonoperating vibration that the drive may experience without incurring physical damage or degradation in performance.

5–20 Hz	0.2-inch displacement (peak-to-peak)
20–400 Hz	4 Gs acceleration (0 to peak)
400–20 Hz	4 Gs acceleration (0 to peak)
20–5 Hz	0.2-inch displacement (peak-to-peak)

1.9 Drive acoustics

Drive acoustics are measured as sound power, using techniques that are generally consistent with ISO document 7779. Measurements are taken under essentially free-field conditions over a reflecting plane, using a total of ten microphones that measure in the 125–8,000 Hz band. This methodology determines broad-band and narrow-band noise, and discrete frequency components. For all tests, the drive is oriented with the cover facing upward.

Mode	Typical	Maximum
Idle (sound power, bels)	3.5	3.8
Seek (sound power, bels)	3.8	4.1
Idle (sound pressure, dBA)	24	28
Seek (sound pressure, dBA)	26	30

1.10 Reliability

Nonrecoverable read errors	1 per 10^{13} bits read
Mean time between failures	350,000 power-on hours (nominal power, at sea level, 40°C ambient temperature)
Contact start-stop cycles	50,000 cycles (at nominal voltage and 40°C ambient temperature, with 120 cycles per hour and a 50% duty cycle)
Preventive maintenance	None required
Service life	5 years

1.11 Agency certification

1.11.1 Safety certification

The drive is recognized in accordance with UL 1950 and CSA C22.2 (950-M89) and meets all applicable sections of IEC 380, IEC 435, IEC 950, VDE 0806/08.81 and EN 60950 as tested by TUV-Rheinland, North America.

1.11.2 Electromagnetic Compatibility

Hard drives that display the CE marking comply with European Union requirements specified in Electromagnetic Compatibility Directive 89/336/EEC as amended by Directive 92/31/EEC of 28 April 1992 and Directive 93/68/EEC of 22 July 1993.

Seagate uses an independent laboratory to confirm compliance with the EC directives specified in the previous paragraph. Drives are tested in representative end-user systems using 80486, Pentium and PowerPC microprocessors. Although CE-marked Seagate drives comply with the directives when used in the test systems, we cannot guarantee that all systems will comply with the directives. The drive is designed for operation inside a properly designed enclosure, with properly shielded I/O cable (if necessary) and terminators on all unused I/O ports. The computer manufacturer or system integrator should confirm EMC compliance and provide CE marking for their products.

1.11.3 FCC verification

These drives are intended to be contained solely within a personal computer or similar enclosure, not attached as an external device. As such, each drive is considered to be a subassembly even when it is individually marketed to the customer. As a subassembly, no Federal Communications Commission verification or certification of the device is required.

Seagate Technology, Inc. has tested this device in enclosures as described above to ensure that the total assembly (enclosure, disc drive, motherboard, power supply, etc.) complies with the limits for a Class B computing device, pursuant to Subpart J, Part 15 of the FCC rules. Operation with noncertified assemblies is likely to result in interference to radio and television reception.

Radio and Television Interference. This equipment generates and uses radio frequency energy and, if not installed and used in strict accordance with the manufacturer's instructions, may cause interference to radio and television reception.

This equipment is designed to provide reasonable protection against such interference in a residential installation. However, there is no guarantee that interference will not occur in a particular installation. If this equipment does cause interference to radio or television reception, which can be determined by turning the equipment on and off, try one or more of the following corrective measures:

- Reorient the receiving antenna.
- Move the device to one side or the other of the radio or TV.
- Move the device farther away from the radio or TV.
- Plug the computer into a different outlet so that the receiver and computer are on different branch outlets.

If necessary, you should consult your dealer or an experienced radio/television technician for additional suggestions. You may find the following booklet from the Federal Communications Commission helpful: *How to Identify and Resolve Radio-Television Interference Problems*. This booklet is available from the Superintendent of Documents, U.S. Government Printing Office, Washington, DC 20402. Refer to publication number 004-000-00345-4.

2.0 Drive mounting and configuration

2.1 Handling and static-discharge precautions

After unpacking, and before installation, the drive may be exposed to potential handling and ESD hazards. You must observe standard static-discharge precautions. A grounded wrist-strap is recommended.

Handle the drive only by the sides of the head/disc assembly. Avoid contact with the printed circuit board, all electronic components and the interface connector. Do not apply pressure to the top cover. Always rest the drive on a padded antistatic surface until you mount it in the host system.

2.2 Jumper settings

2.2.1 Master/slave configuration

You must establish a master/slave relationship between two drives that are attached to a single AT bus. You can configure a drive to become a master or slave by setting the master/slave jumpers, as described below and shown in Figure 2 on page 18.

Alternatively, you can configure the drive as a master or slave using the cable-select option. This requires a special daisy-chain cable that grounds pin 28 (CSEL) on one of its two drive connectors. If you attach the drive to the grounded CSEL connector, it becomes a master. If you attach the drive to the ungrounded CSEL connector, it becomes a slave. To use this option, the host system and both drives must support cable-select and both drives must be configured for cable-select.

For the master drive to recognize the slave drive using the DASP $\bar{}$ signal, the slave drive must assert the DASP $\bar{}$ signal at power up, and the master drive must monitor DASP $\bar{}$ at power up.

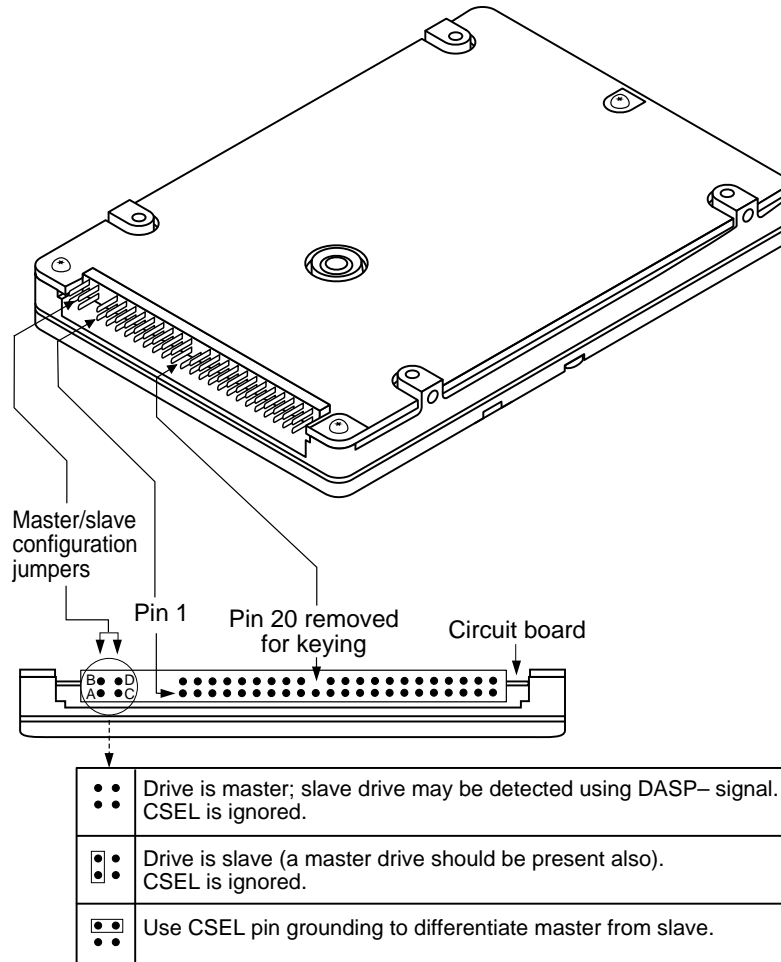

Figure 2. Connector and master/slave jumper setup

2.3 Remote LED configuration

The drive indicates activity to the host through the DASP– line (pin 39) on the ATA interface. This line may be connected to a drive status indicator driving an LED at 5V. The line has a 30 mA nominal current limit. Most external LEDs, however, are sufficiently bright at 15 mA. Because the LED drops 1.7 volts, we recommend that you place a 200-ohm resistor in series with the LED to limit the current to 15 mA.

2.4 Drive mounting

You can mount the drive in any orientation using four screws in the four side-mounting or four bottom-mounting holes. Allow a minimum clearance of 0.030 inches (0.76 mm) around the entire perimeter of the drive for cooling. The drive conforms to the industry-standard SFF-8200 mounting specifications and requires the use of SFF-8200-compatible connectors in direct-mounting applications. See Figures 3 and 4 on pages 20 and 21 for drive mounting dimensions.

Caution. This drive needs sufficient airflow so that the maximum surface temperature at the center of the top cover of the drive does not exceed 62 degrees C (144 degrees F).

Caution. To avoid damaging the drive, use M3X0.5 *metric* mounting screws *only*. Do not insert mounting screws more than 0.118 inches (2.99 mm) into side holes or 0.098 inches (2.49 mm) into bottom mounting holes. Do not overtighten the screws (maximum torque: 3 inch-lb).

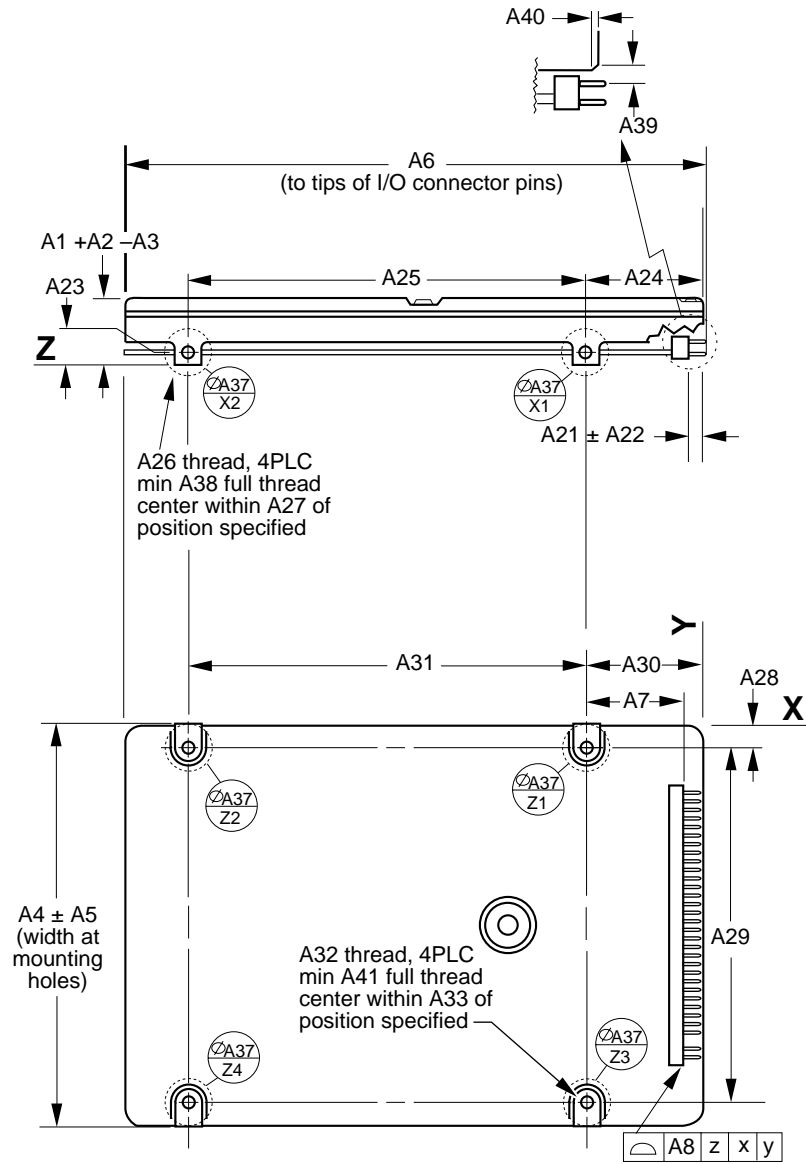

**Figure 3. Drive mounting dimensions—side and bottom view
(for dimension specifications, see table on pages 21 and 22).**

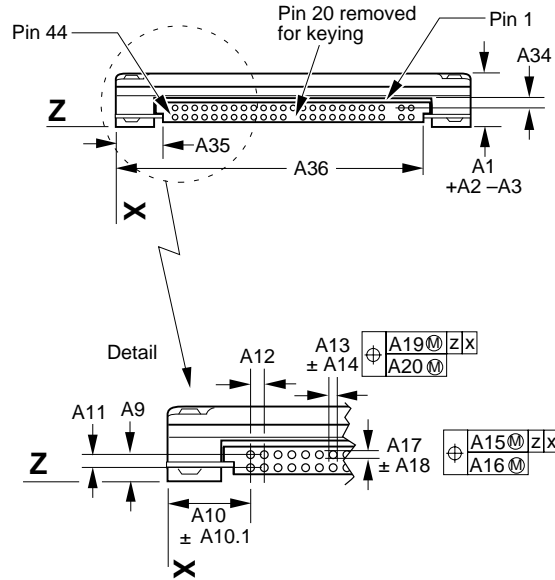

Figure 4. Drive mounting dimensions—end view (for dimension specifications, see table below).

Mounting dimension specifications			
Dim.	Description	inches	mm
A1	Drive height	0.499	12.70
A2	+ tolerance on drive height	0.008	0.20
A3	- tolerance on drive height	0.008	0.20
A4	Drive width at mounting holes	2.750	69.85
A5	+ and - tolerance on drive width at mounting holes	0.010	0.25
A6	Maximum drive length (includes connector pins)	3.974	100.94
A7	Front-to-back connector location	0.403	10.2
A8	Allowable range, front-to-back connector location	0.039	1.00
A9	Top-to-bottom connector location, pin center line	0.157	3.99
A10	Side-to-side connector location, pin center line	0.399	10.14
A10.1	+ and - tolerance, side-to-side connector location	0.015	0.38
A11	Top-to-bottom pin spacing	0.079	2.00
A12	Side-to-side pin spacing	0.079	2.00
A13	Pin side-to-side dimension	0.020	0.50
A14	+ and - tolerance on pin side-to-side dimension	0.002	0.05
A15	Allowable range, side-to-side connector location	0.030	0.75

continued

continued from previous page

Mounting dimension specifications			
Dim.	Description	inches	mm
A16	Allowable range, side-to-side, pins within connector	0.003	0.08
A17	Pin top-to-bottom dimension	0.020	0.50
A18	+ and – tolerance on pin top-to-bottom dimension	0.002	0.05
A19	Allowable range, top-to-bottom connector location	0.020	0.50
A20	Allowable range, top-to-bottom, pins in connector	0.003	0.08
A21	Connector pin length	0.152	3.86
A22	+ and – tolerance on pin length	0.008	0.20
A23	Side mounting-hole height	0.118	3.00
A24	Front-to-back location of side mounting holes	0.551	14.0
A25	Front-to-back distance between side mounting holes	3.016	76.6
A26	Thread description, side mounting holes	N/A	M3
A27	Diameter of cyl. into which hole center must fall	0.020	0.50
A28	Distance between side of drive and center of nearest bottom mounting holes (on pin-44 side)	0.160	4.06
A29	Side-to-side distance between bottom mounting holes	2.430	61.72
A30	Front-to-back location of bottom mounting holes	0.551	14.0
A31	Front-to-back distance between bottom mounting holes	3.016	76.6
A32	Thread description, bottom mounting holes	N/A	M3
A33	Diameter of cyl. into which hole center must fall	0.020	0.50
A34	Min. vertical clearance for mating connector	0.039	1.00
A35	Max. side-to-side distance from pin-44 edge of HDA near I/O connector to start of clearance for mating connector	0.315	8.00
A36	Min. side-to-side clearance from pin-44 edge of I/O connector to any object interrupting clearance of mating connector	2.370	60.20
A37	Diameter of datum targets and reference areas	0.315	8.00
A38	Min. thread depth, side mounting holes	0.118	3.00
A39	Min. pin centerline to chamfer above connector	0.049	1.25
A40	Min. chamfer above connector	0.010	0.25
A41	Min. thread depth, bottom mounting holes	0.098	2.50

2.5 ATA interface connector

The drive connector is a 44-conductor connector with 2 rows of 22 male pins on 0.079-inch (2 mm) centers (see Figure 4 on page 21 and Figure 5). The mating cable connector is a 44-conductor, nonshielded connector with 2 rows of 22 female contacts on 0.079-inch (2 mm) centers. The connectors should provide strain relief and should be keyed with a plug in place of pin 20.

These drives are designed to support the industry-standard SFF-8200 mounting specifications. When installing these drives in fixed mounting applications, use only SFF-compatible connectors, such as Molex part number 87368-442x. For applications that involve flexible cables or printed circuit cables (PCCs), use Molex part number 87259-4413 or equivalent to connect the drive to the system. Select a connector that provides adequate clearance for the master/slave configuration jumpers if the application requires the use of such jumpers. The ATA interface cable should be no more than 18 inches long.

Note. Per SFF 8004 specifications, the I/O connector pins may extend up to 0.015 inches beyond the edge of the head/disc assembly.

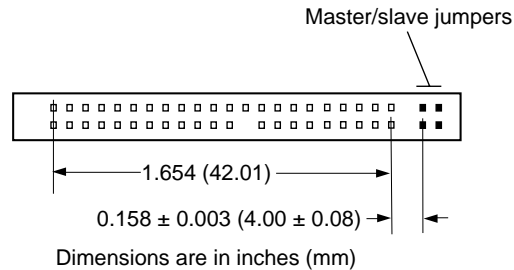

Figure 5. ATA interface connector dimensions (non-SFF dimension, for reference only)

3.0 ATA Attachment-3 Interface (ATA-3)

The drives in this manual comply with the ATA-3 Standard, proposed by the National Committee for Information Technology Standardization (NCITS)—T13. For more information about the committee and the standards, contact the following sources:

- NCTIS internet home page: <http://www.x3.org>
- NCTIS E-mail address: nctis@itic.nw.dc.us
- NCTIS FTP site: <ftp://fission.dt.wdc.com/pub/standards/X3T13>
(for standards and working documents)

Note. On the date of this publication, X3T13/2008D, Revision 7b, dated 27 January 1997, was the latest available revision of Information Technology—AT Attachment-3 Interface (ATA-3).

3.1 ATA interface signals and connector pins

Figure 6 on page 26 summarizes the signals on the ATA interface connector that the drive supports. For a detailed description of these signals, refer to the *Working Draft of the Proposed American National Standard X3T13/2008D Revision 7b, Information Technology AT Attachment-3 Interface (ATA-3)*.

3.1.1 AT bus signal levels

Signals that the drive sends have the following output characteristics at the drive connector:

Logic Low	0.0V to 0.4V
Logic High	2.5V to 5.25V

Signals that the drive receives must have the following input characteristics, measured at the drive connector:

Logic Low	0.0V to 0.8V
Logic High	2.0V to 5.25V

Drive pin #	Signal name	Host pin # and signal description
1	Reset-	1 Host Reset
2	Ground	2 Ground
3	DD7	3 Host Data Bus Bit 7
4	DD8	4 Host Data Bus Bit 8
5	DD6	5 Host Data Bus Bit 6
6	DD9	6 Host Data Bus Bit 9
7	DD5	7 Host Data Bus Bit 5
8	DD10	8 Host Data Bus Bit 10
9	DD4	9 Host Data Bus Bit 4
10	DD11	10 Host Data Bus Bit 11
11	DD3	11 Host Data Bus Bit 3
12	DD12	12 Host Data Bus Bit 12
13	DD2	13 Host Data Bus Bit 2
14	DD13	14 Host Data Bus Bit 13
15	DD1	15 Host Data Bus Bit 1
16	DD14	16 Host Data Bus Bit 14
17	DD0	17 Host Data Bus Bit 0
18	DD15	18 Host Data Bus Bit 15
19	Ground	19 Ground
20	(removed)	20 (No Pin)
21	DMARQ	21 DMA Request
22	Ground	22 Ground
23	DIOW-	23 Host I/O Write
24	Ground	24 Ground
25	DIOR-	25 Host I/O Read
26	Ground	26 Ground
27	IORDY	27 I/O Channel Ready
28	CSEL	28 Cable Select pin
29	DMACK-	29 DMA Acknowledge
30	Ground	30 Ground
31	INTRQ	31 Host Interrupt Request
32	IOCS16-	32 Host 16 Bit I/O
33	DA1	33 Host Address Bus Bit 1
34	PDIAG-	34 Passed Diagnostics
35	DA0	35 Host Address Bus Bit 0
36	DA2	36 Host Address Bus Bit 2
37	CS1FX-	37 Host Chip Select 0
38	CS3FX-	38 Host Chip Select 1
39	DASP-	39 Drive Active / Slave Present
40	Ground	40 Ground
41	Power	41 +5 volts DC (logic)
42	Power	42 +5 volts DC (motor)
43	Ground	43 Ground for power pins
44	Reserved	44 Reserved

Pins 28, 34 and 39 are used for master-slave communication (details shown below).

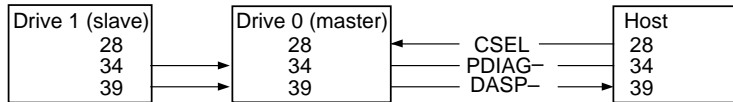

Figure 6. I/O pins and supported ATA signals

3.2 ATA Interface commands

3.2.1 Supported ATA commands

The following table lists supported ATA-standard drive commands. For a detailed description of the ATA commands, refer to the *Draft Proposed ATA-3 Standard*. See Section 3.2.4 on page 34 for details and subcommands used in the S.M.A.R.T. implementation.

Command name	Command code	Supported by Marathon 2130sl and Marathon 1420sl
ATA-standard commands		
Execute Drive Diagnostics	90H	Yes
Format Track	50H	Yes
Identify Drive	ECH	Yes
Initialize Drive Parameters	91H	Yes
NOP	00H	No
Read Buffer	E4H	Yes
Read DMA (w/retry)	C8H	Yes
Read DMA (no retry)	C9H	Yes
Read Long (w/retry)	22H	Yes
Read Long (no retry)	23H	Yes
Read Multiple	C4H	Yes
Read Sectors (w/retry)	20H	Yes
Read Sectors (no retry)	21H	Yes
Read Verify Sectors (w/retry)	40H	Yes
Read Verify Sectors (no retry)	41H	Yes
Recalibrate	10H	Yes
Seek	70H	Yes
Set Features	EFH	Yes
Set Multiple Mode	C6H	Yes

continued

continued from previous page

Command name	Command code	Supported by Marathon 2130sl and Marathon 1420sl
Execute S.M.A.R.T. Command	B0H	Yes
Write Buffer	E8H	Yes
Write DMA (w/retry)	CAH	Yes
Write DMA (no retry)	CBH	Yes
Write Long (w/retry)	32H	Yes
Write Long (no retry)	33H	Yes
Write Multiple	C5H	Yes
Write Same	E9H	No
Write Sectors (w/retry)	30H	Yes
Write Sectors (no retry)	31H	Yes
Write Verify	3CH	No
Drive Security commands		
Security Set Password	F1H	Yes
Security Unlock	F2H	Yes
Security Erase Prepare	F3H	Yes
Security Erase Unit	F4H	Yes
Security Freeze Lock	F5H	Yes
Security Disable Password	F6H	Yes
Power-management commands		
Check Power Mode	98H or E5H	Yes
Idle	97H or E3H	Yes
Idle Immediate	95H or E1H	Yes
Sleep	99H or E6H	Yes
Standby	96H or E2H	Yes
Standby Immediate	94H or E0H	Yes

The following commands contain drive-specific features that may not be described in the *Draft Proposed ATA-3 Standard*.

3.2.2 Identify Drive command

The Identify Drive command (command code ECH) transfers information about the drive to the host after power up. The data is organized as a single 512-byte block of data, the contents of which are shown in the table below. All reserved bits or words should be set to zero. Parameters listed with an "x" are drive-specific or vary with the state of the drive. See Section 1 of this manual for default parameter settings for the Marathon 2130sl and 1420sl.

Word	Description	Contents
0	Configuration information: Bit 6: fixed drive	0040H
1	Number of fixed cylinders (default logical emulation): 4,191 (ST92130AG) 2,794 (ST91420AG)	105FH 0AEA H
2	ATA-reserved	0000H
3	Number of heads (default logical emulation): 16	0010H
4	ATA-obsolete	0000H
5	ATA-obsolete	0000H
6	Number of sectors per track (default logical emulation): 63	003FH
7–9	ATA-reserved	0000H
10–19	Serial number: (20 ASCII characters, 0000H = none)	ASCII
20	ATA-obsolete	0000H
21	ATA-obsolete	0000H
22	Number of ECC bytes available (16)	0010H
23–26	Firmware revision (8 ASCII character string): xx = ROM version, ss = RAM version, tt = RAM version	xx.ss.tt

continued

continued from previous page

Word	Description	Contents
27–46	Drive model number: (40 ASCII characters, padded with blanks to end of string)	ST92130AG or ST91420AG
47	Maximum sectors per interrupt on read/write multiple	0010 _H
48	Reserved	0000 _H
49	Standby timer values supported per ATA standard, IORDY supported, IORDY can be disabled	2C00 _H
50	ATA-reserved	0000 _H
51	PIO data-transfer cycle timing mode	0200 _H
52	DMA transfer cycle timing mode (not used)	0000 _H
53	Validity of words 54–58 and words 64–70 (words may be valid)	0003 _H
54	Number of cylinders (current emulation mode)	xxxx _H
55	Number of heads (current emulation mode)	xxxx _H
56	Number of sectors per track (current emulation mode)	xxxx _H
57–58	Number of sectors (current emulation mode)	xxxx _H
59	Number of sectors transferred during a Read Multiple or Write Multiple command	01xx _H
60–61	LBA sectors available: 4,224,878 (ST92130AG) 2,816,352 (ST91420AG)	776E 0040 _H F960 002A _H
62	ATA-obsolete	0000 _H
63	Multiword DMA active/modes supported (see note following)	0x07 _H
64	Advanced PIO modes supported (modes 3 and 4 supported)	0003 _H
65	Minimum multiword DMA transfer cycle time per word (120 nsec)	0078 _H

Word	Description	Contents
66	Recommended multiword DMA transfer cycle time per word (120 nsec)	0078H
67	Minimum PIO cycle time without IORDY flow control (363 nsec)	016BH
68	Minimum PIO cycle time with IORDY flow control (120 nsec)	0078H
69–127	ATA-reserved	0000H
128–159	Seagate-reserved	xxxxH
160–255	ATA-reserved	0000H

Note. The following DMA mode settings are used in word 63 of the Identify Drive command:

Word	Bit	Description (if bit is set to 1)
63	0	Multiword DMA mode 0 available
63	1	Multiword DMA mode 1 available
63	2	Multiword DMA mode 2 available
63	8	Multiword DMA mode 0 currently active
63	9	Multiword DMA mode 1 currently active
63	10	Multiword DMA mode 2 currently active

3.2.3 Set Features command

This command controls the implementation of various features that the drive supports. When the drive receives this command, it sets BSY, checks the contents of the Features register, clears BSY and generates an interrupt. If the value in the register does not represent a feature that the drive supports, the command is aborted. Power-on default has the read look-ahead and write caching features enabled and 4 bytes of ECC. The acceptable values for the Features register are defined as follows:

- 01H Obsolete
- 02H Enable write cache (*default*)
- 03H Set transfer mode (based on value in Sector Count register)
Sector Count register values:
 - 00H Set PIO mode to default (PIO Mode 2), enable IORDY
 - 01H Set PIO mode to default (PIO Mode 2), disable IORDY
 - 08H PIO Mode 0
 - 09H PIO Mode 1
 - 0AH PIO Mode 2 (*default*)
 - 0BH PIO Mode 3
 - 0CH PIO Mode 4
 - 10H Obsolete
 - 11H Obsolete
 - 12H Obsolete
 - 20H Multiword DMA Mode 0
 - 21H Multiword DMA Mode 1
 - 22H Multiword DMA Mode 2
- 04H Enable auto-read reassignment (*default*)
- 33H Not implemented
- 44H Sixteen bytes of ECC apply on read long and write long commands
- 54H Not implemented
- 55H Disable read look-ahead (read cache) feature
- 66H Disable reverting to power-on defaults
- 77H Not implemented
- 81H Obsolete
- 82H Disable write cache
- 84H Not implemented
- 88H Not implemented

99_H Not implemented

9A_H Not implemented

AA_H Enable read look-ahead (read cache) feature (*default*)

AB_H Not implemented

BB_H 4 bytes of ECC apply on read long and write long commands
(*default*)

CC_H Enable reverting to power-on defaults (*default*)

At power-on or after a hardware reset, the default values of the features are as indicated above. A software reset also changes the features to default values unless a 66_H command has been received.

3.2.4 S.M.A.R.T. commands

Self-Monitoring, Analysis and Reporting Technology (S.M.A.R.T.) is an emerging technology that provides near-term failure prediction for disc drives. When S.M.A.R.T. is enabled, the Seagate drive monitors predetermined drive attributes that are susceptible to degradation over time. If a failure is likely to occur, S.M.A.R.T. makes a status report available so that the host can prompt the user to back up data on the drive. Not all failures are predictable. S.M.A.R.T. predictability is limited to the attributes the drive can monitor. For more information on S.M.A.R.T. commands and implementation, refer to Section 3 of NCITS-T13 publication, Information Technology AT Attachment-3 Interface (ATA-3), Revision 7b or later.

These drives are shipped with S.M.A.R.T. features disabled. You must have a recent BIOS or software package that supports S.M.A.R.T. to enable the feature. The table below shows the S.M.A.R.T. command codes that these drives use.

Before executing a S.M.A.R.T. command by writing B0_H to the Command Register, the host must do the following:

- Write the value 4F_H to Cylinder_Low register.
- Write the value C2_H to the Cylinder_High register.
- Write the appropriate S.M.A.R.T. code to the Features register, as shown in the table below:

Code in Features Register	S.M.A.R.T. Command	Supported by Marathon 2130sl and Marathon 1420sl
D8 _H	Enable S.M.A.R.T. Operations	Yes
D9 _H	Disable S.M.A.R.T. Operations	Yes
DA _H	Return S.M.A.R.T. Status	Yes

Note. If an appropriate code is not written to the Features register, the command will be aborted and 0x04 (abort) will be written to the Error register.

3.2.5 Drive-Security commands

The drive-security commands provide a password-based security system to prevent unauthorized access to a disc drive.

During manufacturing, the master password, SEAGATE, is set for the drive, and the lock function is disabled. The system manufacturer or dealer may set a new master password using the Security Set Password command (F1H), without enabling the lock function. Before a user password is entered, the drive rejects all security commands except Security Set Password.

When you set a password, the drive automatically enters lock mode (lock mode is enabled) the next time it is powered on. When lock mode is enabled, the drive rejects all media-access commands until you enter the correct user password, completing a Security Unlock command.

The drive supports two levels of security: high security and maximum security. In high-security mode, if you forget your password, you can still access the data by entering the master password. In maximum security mode, if you forget your password, you cannot access the data. However, in maximum security mode, you can erase all data on the drive and reinitialize the drive using the Erase Unit command (F4H). You must enter the master password to complete an Erase Unit command.

The Freeze Lock command (F5H) prevents you from changing security features. If, during normal drive operation, the Freeze Lock command is executed, all normal drive commands are implemented, but the security commands Disable Password, Erase Unit, Set Password and Unlock, cannot be completed.

See the ATA-3 specification (Document X3T13/2008D) for additional details on the drive-security commands.

Appendix. Compatibility notes

ECC testing

When a Marathon 2130sl or Marathon 1420sl performs hardware-based ECC error correction on-the-fly, the drive does not report an ECC error. This allows ECC correction without degrading drive performance. Some older drive diagnostic programs test ECC features by creating small data errors and then checking to see if they are reported. Such tests, when run on these drives, may incorrectly report an ECC detection failure because the drive hardware corrects the data automatically, avoiding the error rather than reporting it. Such a report does not indicate a drive malfunction.

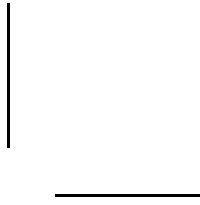
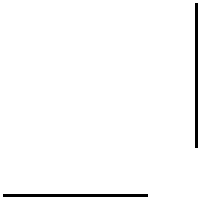

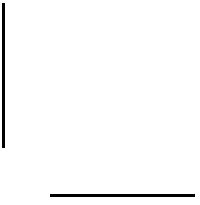
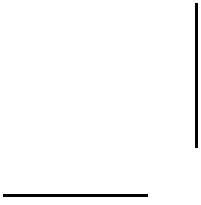



Seagate Technology, Inc.
920 Disc Drive, Scotts Valley, California 95066, USA

Publication Number: 20401053-001, Rev. A, Printed in USA